



# BEDPAN WASHER

## Z85500-WM-EVB-HK-SE-SH-VC

### TAG

#### Engineering Specifications: Zurn AquaSpec® Z85500-WM-EVB-HK-SE-SH-VC

Polished chrome-plated brass wall mounted, self-closing double pedal bedpan washer with two 1/2" angle stop inlets on 2-1/2" [64mm] centers and one 1/2" male outlet. Unit is furnished with an elevated vacuum breaker, a flanged wall supply, a 4' [122cm] vinyl spray hose with an insulated 6" [152mm] handle, hook and volume control.

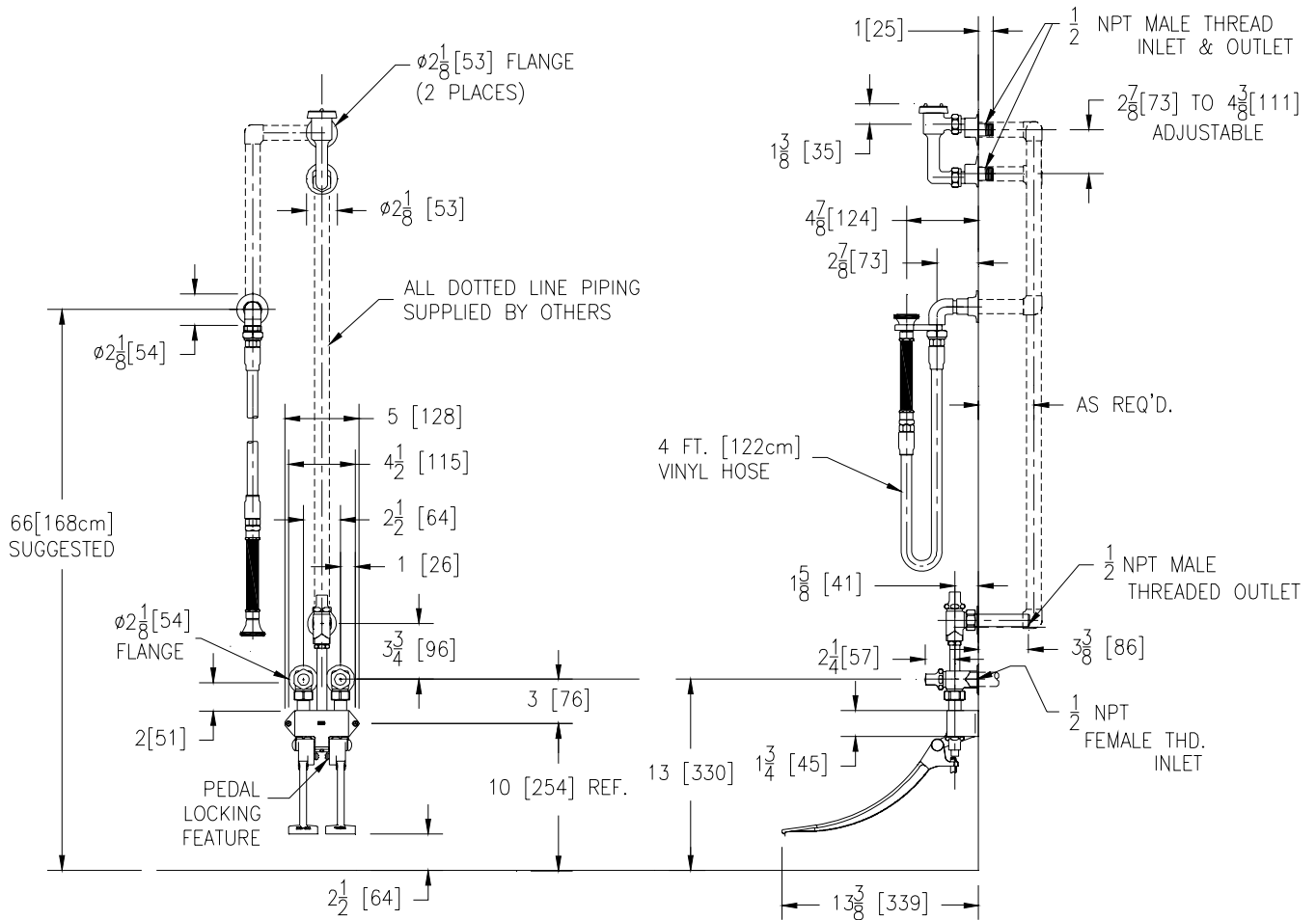

Note: All dimensions are for reference only. Do not use for pre-plumbing



[www.GreenSpec.com](http://www.GreenSpec.com)

#### OPTIONAL ACCESSORIES

Suffix	Description
___-SH1	Spray Hose with Insulated Handle
___-SH2	Spray Hose with Angled Head and Insulated Handle
___-SH3	Spray Hose with Angled Head, Insulated Handle and Self-Closing Valve
___-SH4	Spray Hose with Angled Head and Self-Closing Valve

ZURN INDUSTRIES, LLC ♦ COMMERCIAL BRASS OPERATION ♦ 2640 SOUTH WORK STREET ♦ FALCONER NY 14733

Phone: 1-716-665-1132 ♦ Fax: 1-716-665-1135 ♦ World Wide Web: [www.zurn.com](http://www.zurn.com)

In Canada: ZURN INDUSTRIES LIMITED ♦ 3544 Nashua Drive ♦ Mississauga, Ontario L4V1L2 ♦ Phone: 905/405-8272 Fax: 905/405-1292